

These diagrams should be used in  
conjunction with photos of your loco

for treatment of these splasher tops  
see sheet 1. Identical method used  
as for forming Platform/footplate

curved shape forms L strake  
soldered at rear edge of raised band

front piece leans  
back against curved  
part

Roof

side & front edges  
fold up

rear bracing  
piece cut off  
after completion

1/2 etch footplate  
shape alignment  
profile line

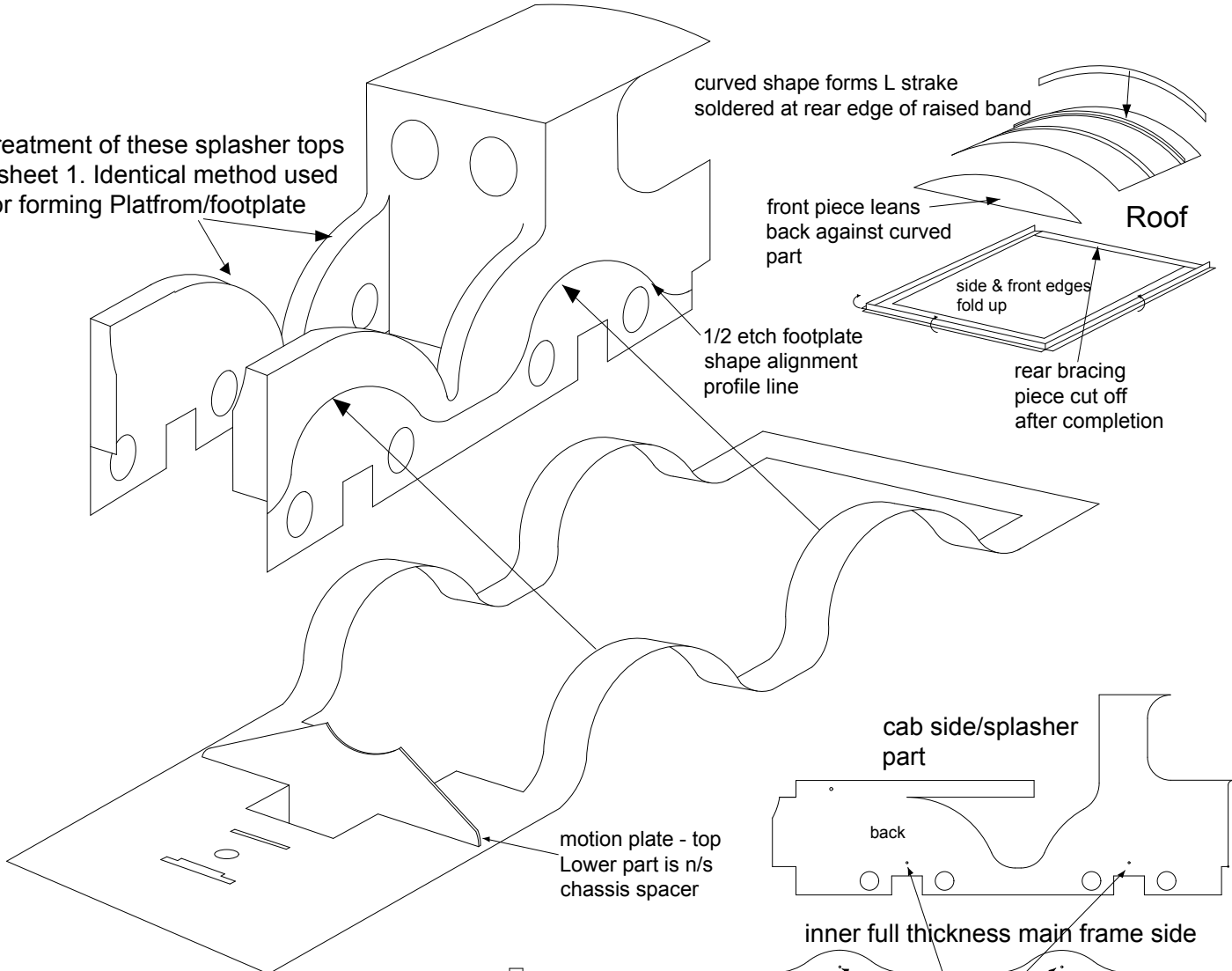

cab side/splasher  
part

back

inner full thickness main frame side

centre  
alignment holes

outer 1/2 etched frame layer

note different lengths

spring strap  
holes

**Driving Axlebox Construction**

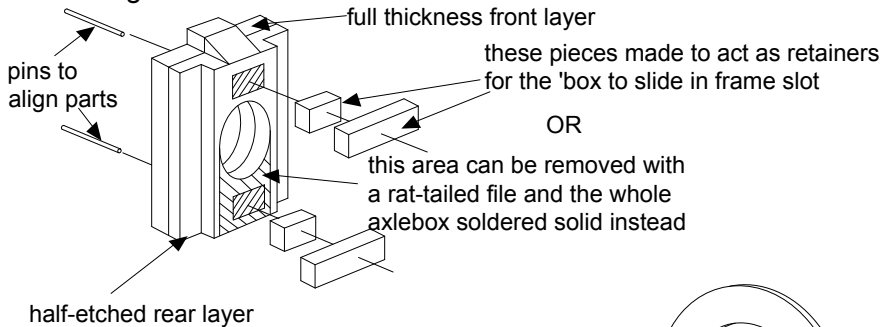

**smokebox frame**

