

# E.B.Models Slotted Signals Instruction Diagrams - NOT TO SCALE

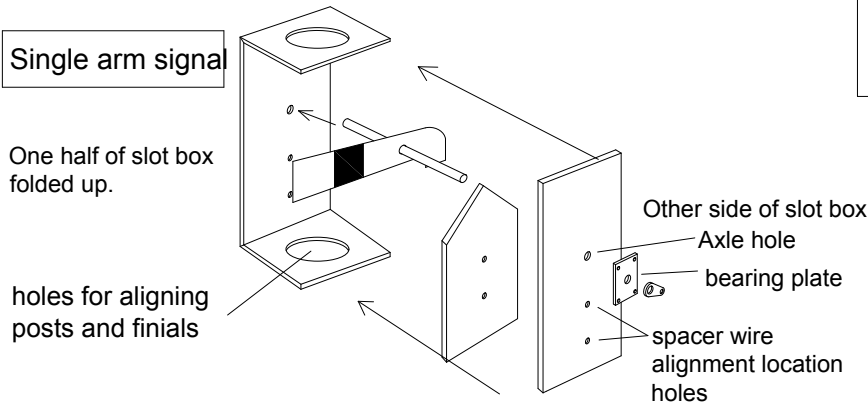

**Slot Boxes:**  
(Edge moulding omitted for clarity)

For tandem signals - both single and bi-directional, use the same construction process with each position

**Bi-directional signals:**  
(spacers omitted for clarity)

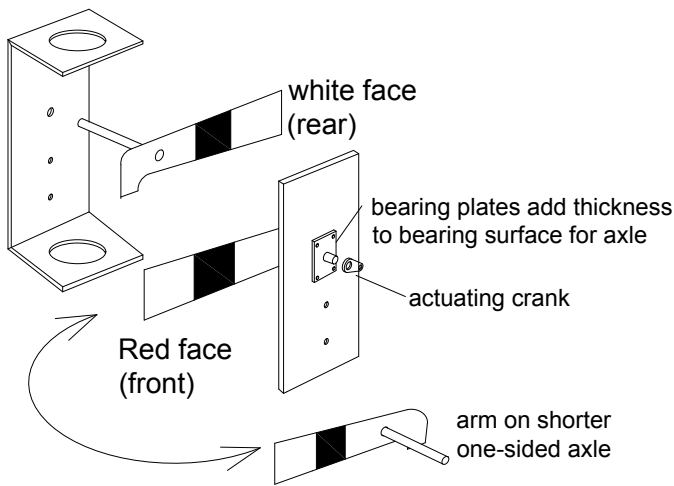

**Post-mounted rotating signal**

signal faces removed for clarity

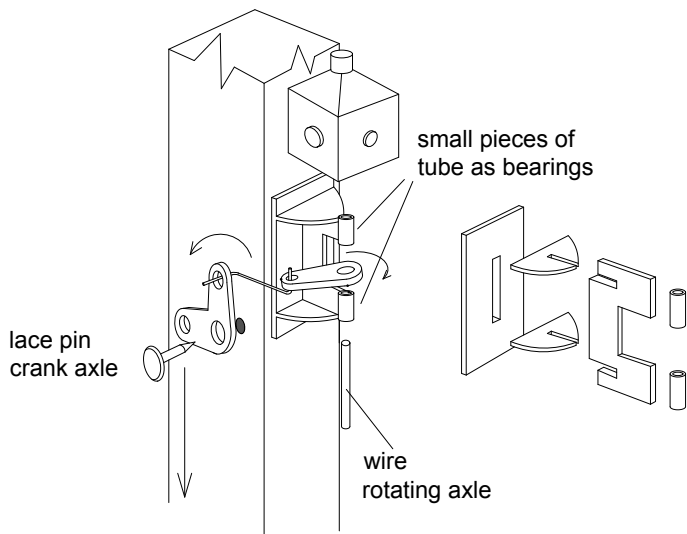

**Ground Signals: later style frame**

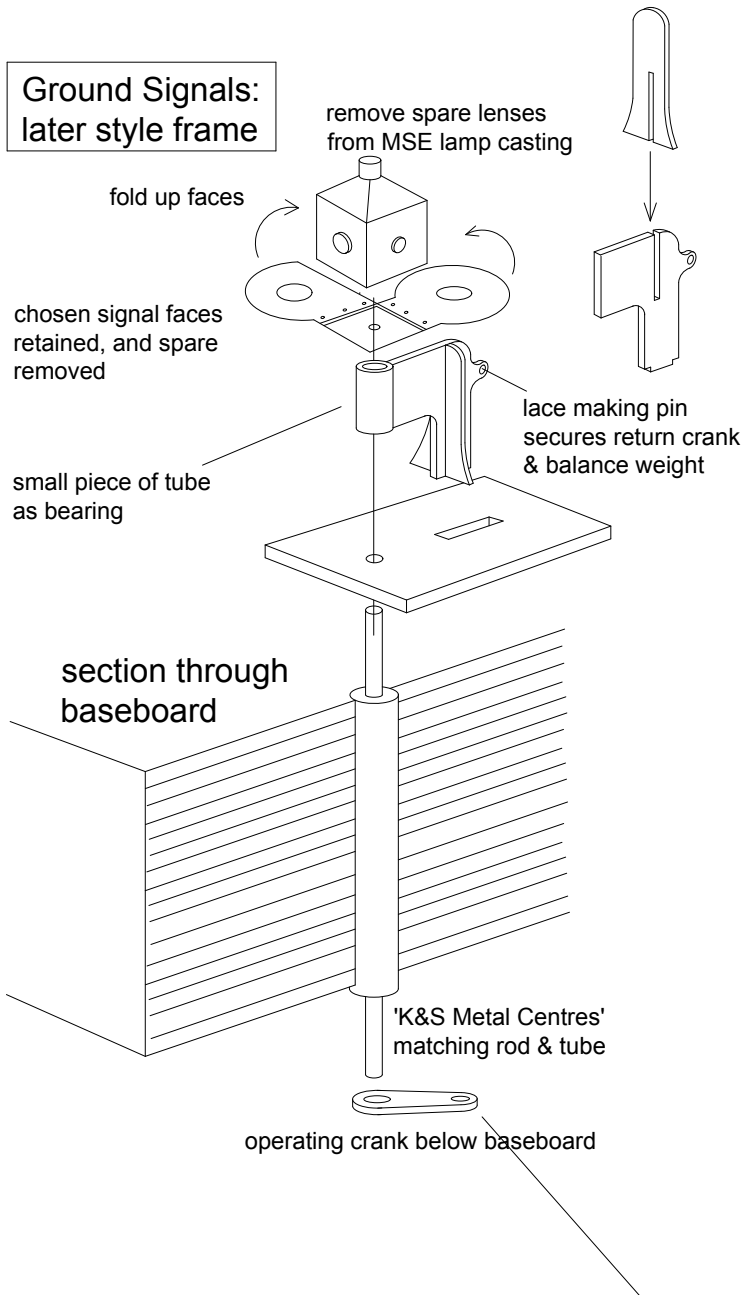

signal control leads to choice of lever frame

All joints that are not required to move are soldered with 145deg solder

