

E.B.Models Slotted Signals Instruction Diagrams 2 - NOT TO SCALE

Construction of Brackets

Off-hand single doll large bracket

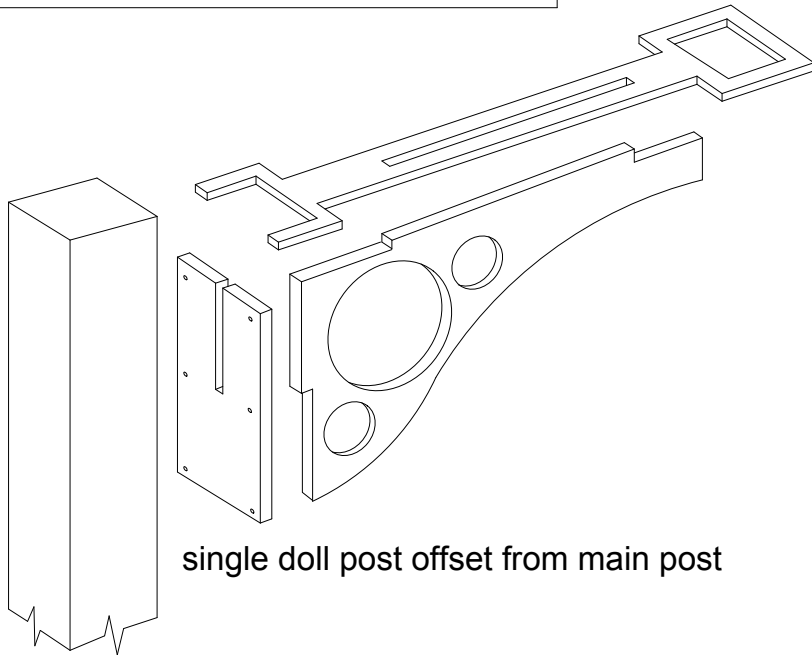

Balance weight return lever and frame (ground signals)

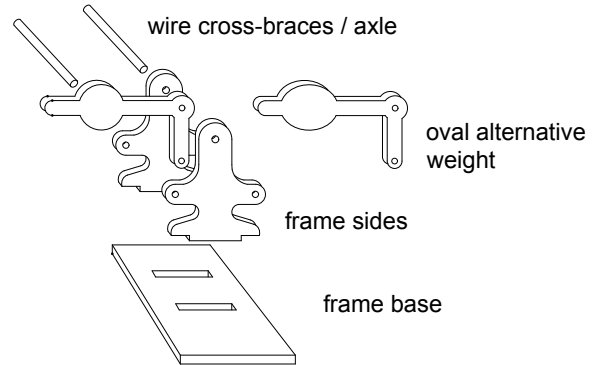

Equal 2 doll bracket

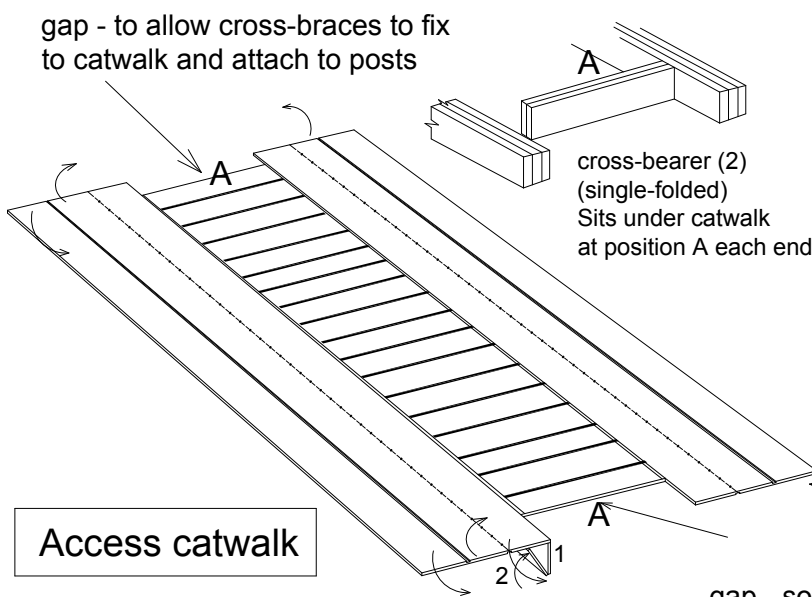
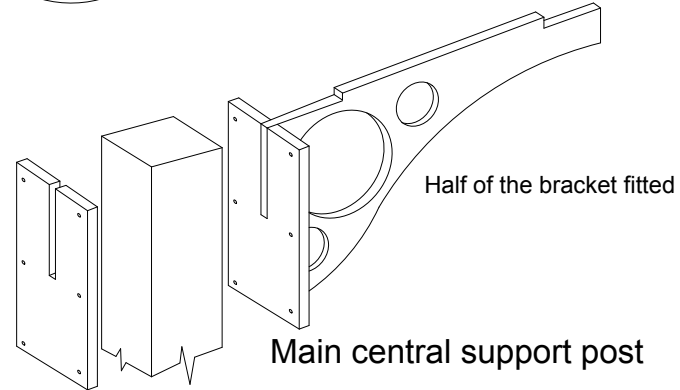
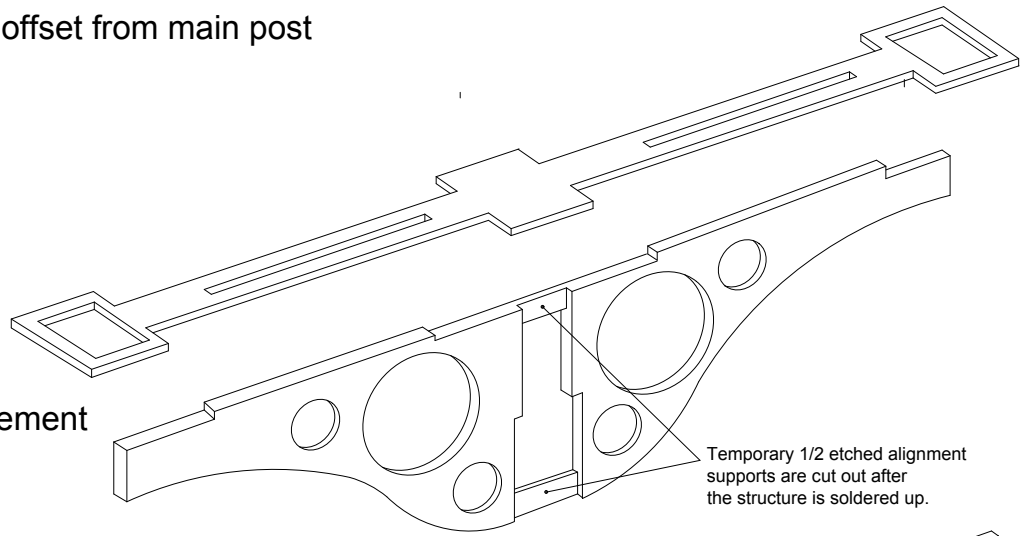

- bend outer section under
- bend centre section upwards
- bend inner section down

gap - some frets do not have this gap. Simply remedied by removing one slat each end

